



CAPRI 100

FICHE TECHNIQUE



Fabriqué en France



www.senest.fr

Senest est une marque de Parasols Wongleon

PARASOLS
wongleon[®]

www.wongleon.fr

CAPRI 100

DÉTAILS DU PRODUIT

- TOILE** Toile haut de gamme acrylique, déperlante et anti-moisissure.
- MONTURE** Monture en aluminium anodisé ou laqué série **EN-AW-6060-T6**. 8 baleines 25x40x2mm. À partir de 500x500, 12 baleines 25x40x2mm.
- MÂT** Mât télescopique central en aluminium anodisé ou laqué série **EN-AW-6005-T6** de 100xø5mm.
- LES +** Ouverture manivelle et freinage.
Personnalisation en option.
Bavolets en option

DIFFÉRENTS MODÈLES

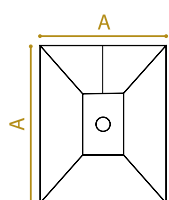
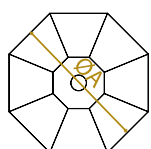
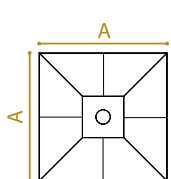
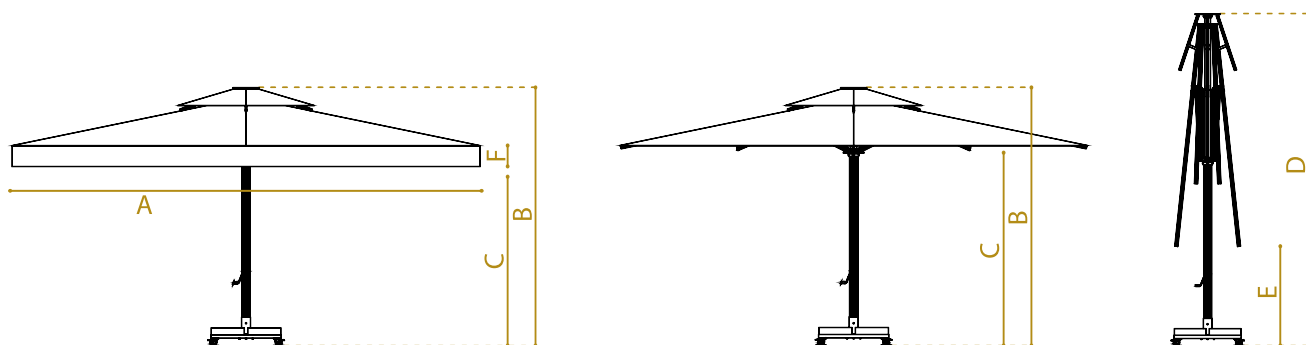

	A	B	C	D	E	F
400x400		306	215	416	122	25
450x450		317	215	423	135	25
500x500		364	225	520	145	39
550x550*		370	225	530	120	40
600x600*		376	235	536	100	42
350x450		310	215	416	135	25
400x500		355	225	512	145	30
450x550*		355	225	514	120	35
500x600*		360	235	515	110	41

* 12 baleines

LIEUX D'UTILISATION



HÔTELLERIE
RESTAURATION

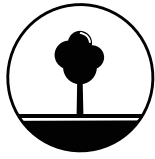

ESPACES VERTS



TERRASSES

DÉTAILS



Noix coulissante en métal



Manivelle



Finition galon tressé acrylique
teinté dans la masse
Couture zigzag

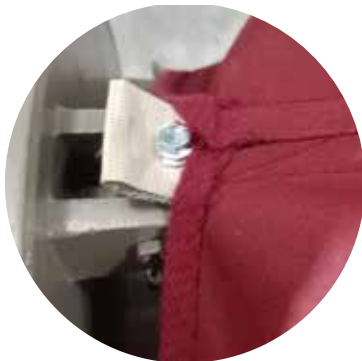

Pattes en PVC renforcé

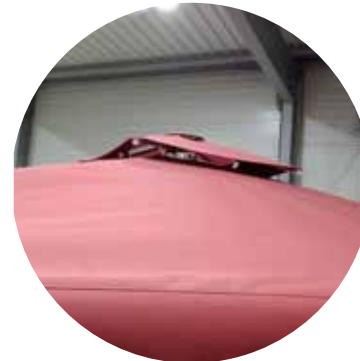

Chapeau

PIEDS COMPATIBLES



Pied marbre



Pied pliable

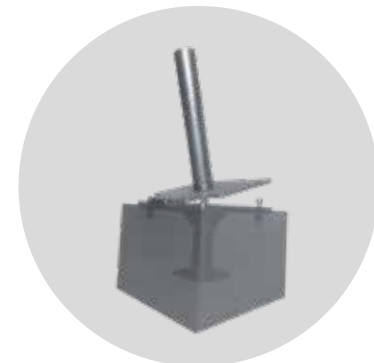

Pied pliable
encastrable



SENEST

Zone Inova 3000
88150 THAON-LES-VOSGES
Tél : 03 29 29 60 00
info@senest.fr



SENEST
PARASOLS CHR

www.senest.fr

PARASOLS **wongleon**[®]

www.wongleon.fr